



US 20190058151A1

(19) **United States**

(12) **Patent Application Publication**
ZENG et al.

(10) **Pub. No.: US 2019/0058151 A1**

(43) **Pub. Date: Feb. 21, 2019**

(54) **ORGANIC LIGHT-EMITTING DIODE DISPLAY**

Publication Classification

(71) Applicant: **Shenzhen China Star Optoelectronics Semiconductor Display Technology Co., Ltd., Guangdong (CN)**

(51) **Int. Cl.**
H01L 51/52 (2006.01)
H01L 51/50 (2006.01)
H01L 27/32 (2006.01)

(72) Inventors: **Weijing ZENG, Guangdong (CN); Baixiang HAN, Guangdong (CN)**

(52) **U.S. Cl.**
CPC *H01L 51/5221* (2013.01); *H01L 51/5206* (2013.01); *H01L 2251/5307* (2013.01); *H01L 27/3276* (2013.01); *H01L 27/3213* (2013.01); *H01L 51/5036* (2013.01)

(21) Appl. No.: **15/577,247**

(57) **ABSTRACT**

(22) PCT Filed: **Oct. 26, 2017**

An organic light-emitting diode display is provided. The organic light-emitting diode display has an anode layer, an organic layer disposed on the anode layer, and a cathode layer disposed on the organic layer and comprising a plurality of cathode lines. The organic light-emitting diode display comprises a plurality of pixel columns corresponding to the cathode lines. Pixels in the same pixel column have the same color, and the cathode lines corresponding to the pixel columns having different colors are inputted with different cathode voltages, respectively.

(86) PCT No.: **PCT/CN2017/107828**

§ 371 (c)(1),

(2) Date: **Nov. 27, 2017**

(30) **Foreign Application Priority Data**

Aug. 16, 2017 (CN) 201710699528.6

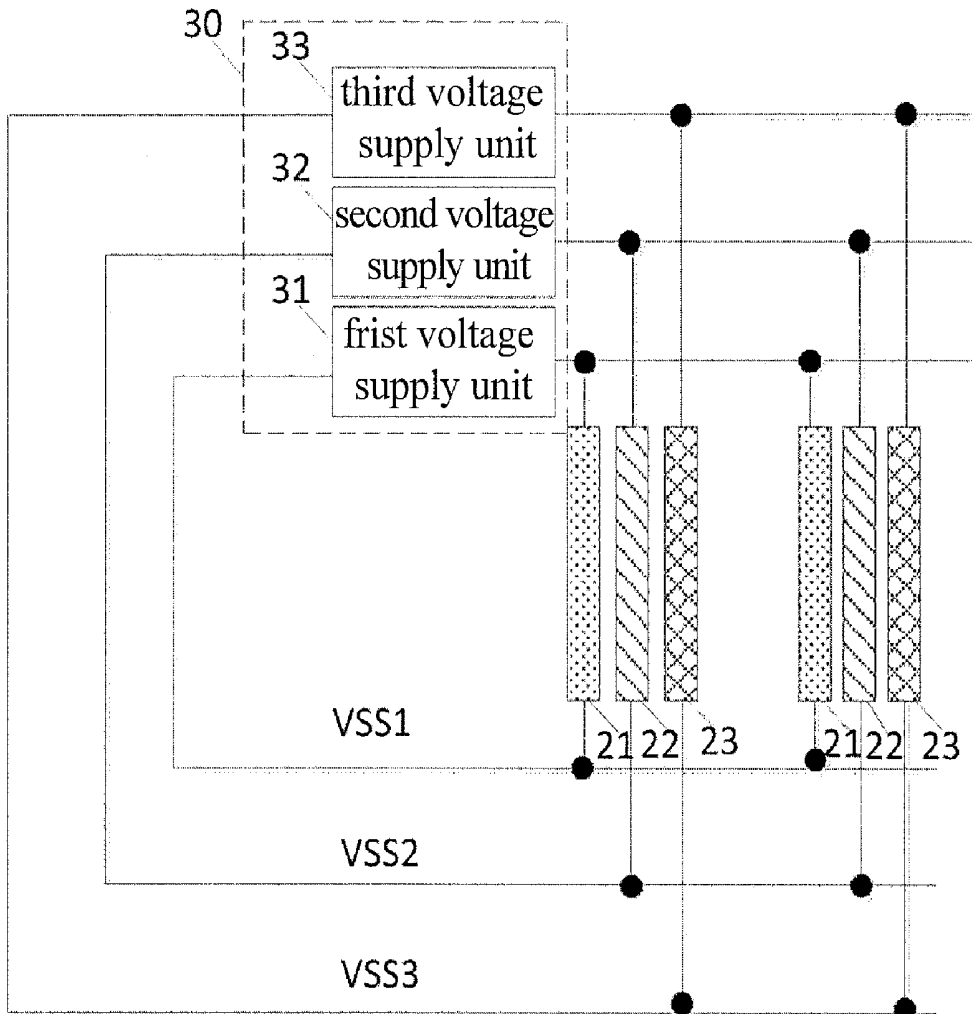

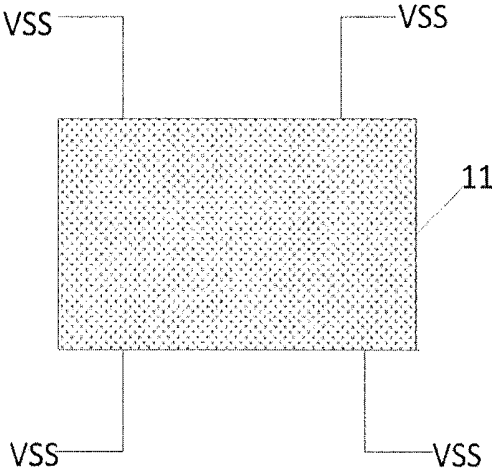

FIG. 1
PRIOR ART

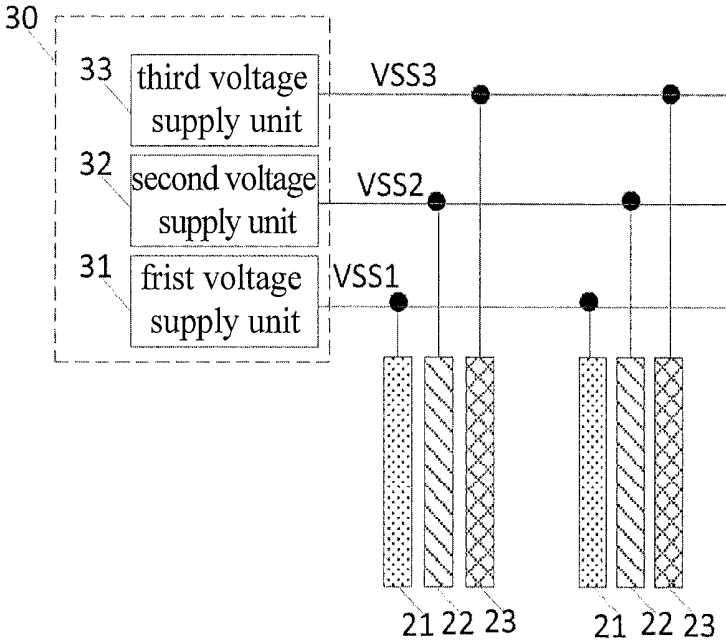

FIG. 2

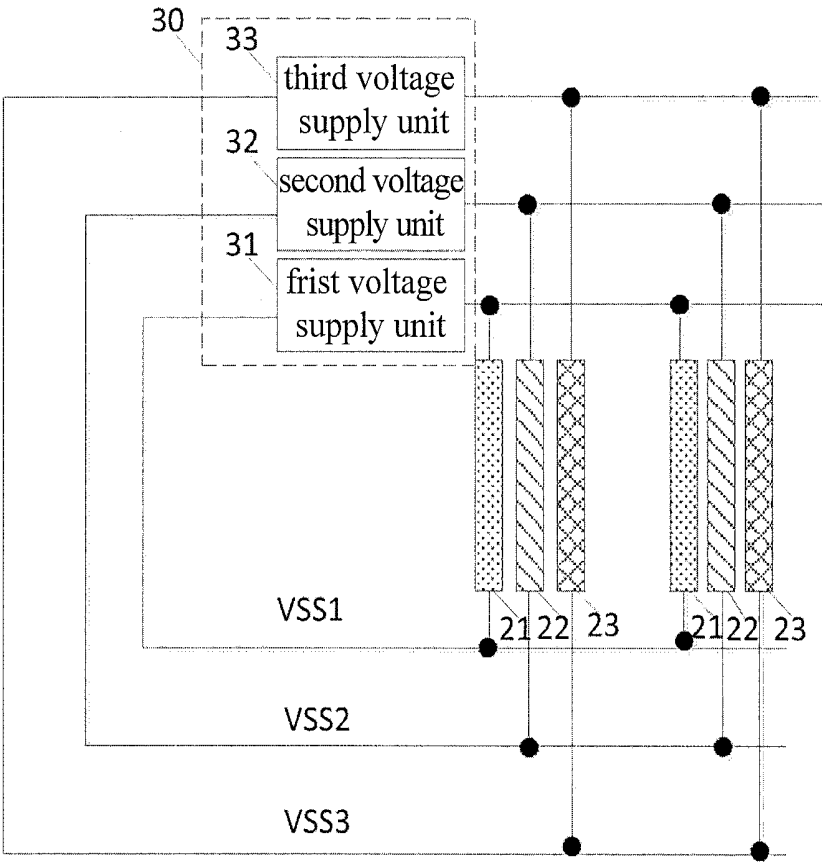

FIG. 3

ORGANIC LIGHT-EMITTING DIODE DISPLAY

FIELD OF INVENTION

[0001] The present disclosure relates to a technical field of displays, and in particular to an organic light-emitting diode display.

BACKGROUND OF INVENTION

[0002] Organic Light-Emitting Diode (OLED) display panels have some features, such as being self-luminous, high brightness, wide viewing angles, high contrast, being flexible, and having low power consumption. Therefore, they are widely used in mobile phone screens, computer monitors, and full color TVs. OLED display panels comprise self-emitting OLED elements, wherein organic light-emitting diodes are current-driven components. Brightness of the panels are driven by current passing through OLED components. OLED cathodes are easily affected by voltage drop (IR drop) so that the current passing through the OLED elements is reduced and affects the display brightness. When the current is greater, the brightness decreases more.

[0003] Adjusting gamma of the panel brightness collects the brightness in different colors and different grayscale voltages, then division of the corresponding grayscale is processed. The division of the grayscale having different colors is determined by IR drop of the corresponding color pixel. However, as shown in FIG. 1, a cathode layer 11 of OLED panel is a layered structure, wherein the cathode layer 11 is inputted the same cathode voltage VSS, and all pixels are connected to a common cathode so that the brightness of the pixel will be affected by the current of the panel and IR drop, and IR drop of the panels are the same. Thus, a difference is generated between actual gamma adjustment and panel brightness so that the panel has color cast.

[0004] As a result, it is necessary to provide an organic light-emitting diode display to solve the problems existing in conventional technologies, as described above.

SUMMARY OF INVENTION

[0005] An object of the present disclosure is to provide an organic light-emitting diode display which can avoid color cast appearing in the display.

[0006] To achieve the above objects, the present disclosure provides an organic light-emitting diode display, wherein the organic light-emitting diode display comprises: an anode layer; an organic layer disposed on the anode layer; and a cathode layer disposed on the organic layer and comprising a plurality of cathode lines spaced apart from each other, wherein the organic light-emitting diode display comprises a plurality of pixel columns corresponding to the cathode lines. Pixels in the same pixel column have the same color, the cathode lines corresponding to the pixel columns having different colors are inputted with different cathode voltages, respectively. The organic light-emitting diode display further comprises a voltage supply module configured to supply cathode voltages, and the cathode lines connect to the voltage supply module.

[0007] In one embodiment of the present disclosure, an end of the cathode lines connects to the voltage supply module.

[0008] In one embodiment of the present disclosure, two ends of the cathode lines connect to the voltage supply module.

[0009] In one embodiment of the present disclosure, the voltage supply module comprises a first voltage supply unit configured to supply a first cathode voltage, a second voltage supply unit configured to supply a second cathode voltage, and a third voltage supply unit configured to supply a third cathode voltage. The pixel columns comprises a red pixel column, a green pixel column, and a blue pixel column, wherein the cathode line corresponding to the red pixel column connects to the first voltage supply unit, the cathode line corresponding to the green pixel column connects to the second voltage supply unit, and the cathode line corresponding to the blue pixel column connects to the third voltage supply unit.

[0010] In one embodiment of the present disclosure, the cathode lines are formed by an evaporation process.

[0011] In one embodiment of the present disclosure, the organic light-emitting diode display further comprises a switch array layer located under the anode layer, and the switch array layer comprises a plurality of switch elements.

[0012] In one embodiment of the present disclosure, the organic light-emitting diode display further comprises an encapsulation layer located on the cathode layer.

[0013] In one embodiment of the present disclosure, the organic light-emitting diode display is a top emission type or a bottom emission type.

[0014] To achieve the above objects, the present disclosure provides an anode layer; an organic layer disposed on the anode layer; and a cathode layer disposed on the organic layer and comprising a plurality of cathode lines, wherein the organic light-emitting diode display comprises a plurality of pixel columns corresponding to the cathode lines. Pixels in the same pixel column have the same color, the cathode lines corresponding to the pixel columns having different colors are inputted with different cathode voltages, respectively.

[0015] In one embodiment of the present disclosure, the organic light-emitting diode display further comprises a voltage supply module configured to supply cathode voltages, and the cathode lines connect to the voltage supply module.

[0016] In one embodiment of the present disclosure, an end of the cathode lines connects to the voltage supply module.

[0017] In one embodiment of the present disclosure, two ends of the cathode lines connect to the voltage supply module.

[0018] In one embodiment of the present disclosure, the voltage supply module comprises a first voltage supply unit configured to supply a first cathode voltage, a second voltage supply unit configured to supply a second cathode voltage, and a third voltage supply unit configured to supply a third cathode voltage. The pixel columns comprises a red pixel column, a green pixel column, and a blue pixel column, wherein the cathode line corresponding to the red pixel column connects to the first voltage supply unit, the cathode line corresponding to the green pixel column connects to the second voltage supply unit, and the cathode line corresponding to the blue pixel column connects to the third voltage supply unit.

[0019] In one embodiment of the present disclosure, the cathode lines are spaced apart from each other.

[0020] In one embodiment of the present disclosure, the cathode lines are formed by an evaporation process.

[0021] In one embodiment of the present disclosure, the organic light-emitting diode display further comprises a switch array layer located under the anode layer, and the switch array layer comprises a plurality of switch elements.

[0022] In one embodiment of the present disclosure, the organic light-emitting diode display further comprises an encapsulation layer located on the cathode layer.

[0023] In one embodiment of the present disclosure, the organic light-emitting diode display is a top emission type or a bottom emission type.

[0024] In the organic light-emitting diode display of the present disclosure, the cathode layer is divided with a plurality of cathode lines, and the cathode lines corresponding to the pixel columns having different colors are inputted with different cathode voltages so that the panel brightness can be adjusted, and color cast can be avoided.

DESCRIPTION OF DRAWINGS

[0025] FIG. 1 is a schematic view of a cathode layer of a traditional organic light-emitting diode display.

[0026] FIG. 2 is a schematic view of a cathode layer of an organic light-emitting diode display according to an embodiment of the present disclosure.

[0027] FIG. 3 is a schematic view of a cathode layer of an organic light-emitting diode display according to another embodiment of the present disclosure.

DETAILED DESCRIPTION OF PREFERRED EMBODIMENTS

[0028] The structure and the technical means adopted by the present invention to achieve the above and other objects can be best understood by referring to the following detailed description of the preferred embodiments and the accompanying drawings. Furthermore, directional terms described by the present invention, such as upper, lower, front, back, left, right, inner, outer, side, longitudinal/vertical, transverse/horizontal, etc., are only directions by referring to the accompanying drawings, and thus the used directional terms are used to describe and understand the present invention, but the present invention is not limited thereto.

[0029] In an embodiment, an organic light-emitting diode display of the present disclosure comprises a plurality of pixel columns, pixels in the same pixel column have the same color, wherein the pixel columns comprise a red pixel column, a green pixel column, and a blue pixel column.

[0030] In the cross-sectional structure, the organic light-emitting diode display of the present disclosure comprises an anode layer, an organic layer, and a cathode layer. The organic layer is disposed on the anode layer, and the cathode layer is disposed on the organic layer.

[0031] Referring to FIG. 2, the cathode layer comprising a plurality of cathode lines 21-23 spaced apart from each other, the cathode lines 21-23 correspond to the pixel columns, respectively. Each of the pixel columns is disposed with a cathode line, wherein the cathode lines are spaced apart from each other, and two adjacent cathode lines are spaced apart so that cathode voltages can be inputted.

[0032] In an embodiment, the cathode line 21 corresponds to the red pixel column, the cathode line 22 corresponds to the green pixel column, and the cathode line 23 corresponds to the blue pixel column. The cathode lines corresponding to

the pixel columns having different colors are inputted with different cathode voltages, respectively, such as the cathode line 21 corresponding to the red pixel column is inputted with a first cathode voltage VSS1, the cathode line 22 corresponding to the green pixel column is inputted with a second cathode voltage VSS2, and the cathode line 23 corresponding to the blue pixel column is inputted with a third cathode voltage VSS3.

[0033] The cathode lines are formed by a mask evaporation process for cathode material.

[0034] The organic light-emitting diode display of the present disclosure further comprises a voltage supply module 30, wherein the voltage supply module 30 is configured to supply cathode voltages. The voltage supply module 30 comprises a first voltage supply unit 31, a second voltage supply unit 32, and a third voltage supply unit 33. The first voltage supply unit 31 is configured to supply the first cathode voltage VSS1, the second voltage supply unit 32 is configured to supply the second cathode voltage VSS2, and the third voltage supply unit 33 is configured to supply the third cathode voltage VSS3.

[0035] An end of the cathode lines 21-23 connects to the voltage supply module 30.

[0036] For example, an end of the cathode line 21 corresponding to the red pixel column connects to the first voltage supply unit 31 for inputting the first cathode voltage VSS1, an end of the cathode line 22 corresponding to the green pixel column connects to the second voltage supply unit 32 for inputting the second cathode voltage VSS2, and an end of the cathode line 23 corresponding to the blue pixel column connects to the third voltage supply unit 33 for inputting the first cathode voltage VSS3.

[0037] The organic light-emitting diode display further comprises a switch array layer, and the switch array layer is located under the anode layer, and the switch array layer comprises a plurality of switch elements.

[0038] The organic light-emitting diode display further comprises an encapsulation layer, and the encapsulation layer is located on the cathode layer.

[0039] The organic light-emitting diode display is a top emission type or a bottom emission type.

[0040] It is understandable that the pixel columns further comprises at least one of a white pixel column or a yellow pixel column. The cathode lines are not limited to the cathode lines described above.

[0041] The cathode layer is divided with a plurality of cathode lines, and the cathode lines corresponding to the pixel columns having different colors are inputted with different cathode voltages VSS so that the collected brightness corresponds to the actual brightness of the panel during adjusting gamma of the panel brightness. Thus, color cast can be avoided.

[0042] In another embodiment, the organic light-emitting diode display of the present disclosure comprises a plurality of pixel columns, wherein pixels in the same pixel column have the same color. The pixel columns comprise a red pixel column, a green pixel column, and a blue pixel column. It is understandable that the pixel columns further comprise at least one of a white pixel column or a yellow pixel column.

[0043] In the cross-sectional structure, the organic light-emitting diode display of the present disclosure comprises an anode layer, an organic layer, and a cathode layer. The organic layer is disposed on the anode layer, and the cathode layer is disposed on the organic layer.

[0044] Referring to FIG. 3, the cathode layer comprising a plurality of cathode lines 21-23, and the cathode lines 21-23 correspond to the pixel columns, respectively. Each of the pixel columns is disposed with a cathode line, wherein the cathode lines are spaced apart from each other, and two adjacent cathode lines are spaced apart so that cathode voltages can be inputted.

[0045] Specifically, the cathode line 21 corresponds to the red pixel column, the cathode line 22 corresponds to the green pixel column, and the cathode line 23 corresponds to the blue pixel column. The cathode lines corresponding to the pixel columns having different colors are inputted with different cathode voltages, respectively, such as the cathode line 21 corresponding to the red pixel column is inputted with a first cathode voltage VSS1, the cathode line 22 corresponding to the green pixel column is inputted with a second cathode voltage VSS2, and the cathode line 23 corresponding to the blue pixel column is inputted with a third cathode voltage VSS3.

[0046] The cathode lines are formed by a mask evaporation process for cathode material.

[0047] The organic light-emitting diode display of the present disclosure further comprises a voltage supply module 30, wherein the voltage supply module 30 is configured to supply cathode voltages. The voltage supply module 30 comprises a first voltage supply unit 31, a second voltage supply unit 32, and a third voltage supply unit 33. The first voltage supply unit 31 is configured to supply the first cathode voltage VSS1, the second voltage supply unit 32 is configured to supply the second cathode voltage VSS2, and the third voltage supply unit 33 is configured to supply the third cathode voltage VSS3.

[0048] Two ends of the cathode lines 21-23 connect to the voltage supply module 30.

[0049] Referring to FIG. 3, two ends of the cathode lines 21-23 connect to the voltage supply module 30, wherein an upper end and a lower end of the cathode line 21 corresponding to the red pixel column connects to the first voltage supply unit 31 for inputting the first cathode voltage VSS1. An upper end and a lower end of the cathode line 22 corresponding to the green pixel column connects to the second voltage supply unit 32 for inputting the second cathode voltage VSS2. An upper end and a lower end of the cathode line 23 corresponding to the blue pixel column connects to the third voltage supply unit 33 for inputting the first cathode voltage VSS3.

[0050] The organic light-emitting diode display further comprises a switch array layer, and the switch array layer is located under the anode layer, and the switch array layer comprises a plurality of switch elements.

[0051] The organic light-emitting diode display further comprises an encapsulation layer, and the encapsulation layer is located on the cathode layer.

[0052] The organic light-emitting diode display is a top emission type or a bottom emission type.

[0053] In the embodiment, the upper end and the lower end of the cathode line are inputted the cathode voltage. Based on above embodiment, voltage drop (IR drop) can be further reduced so that color cast can be avoided better.

[0054] In the organic light-emitting diode display of the present disclosure, the cathode layer is divided with a plurality of cathode lines, and the cathode lines corresponding to the pixel columns having different colors are inputted

with different cathode voltages VSS so that the panel brightness can be adjusted, and color cast can be avoided.

[0055] The present disclosure has been described with preferred embodiments thereof and it is understood that many changes and modifications to the described embodiments can be carried out without departing from the scope and the spirit of the invention that is intended to be limited only by the appended claims.

What is claimed is:

1. An organic light-emitting diode display, comprising: an anode layer;

an organic layer disposed on the anode layer; and a cathode layer disposed on the organic layer and comprising a plurality of cathode lines spaced apart from each other, wherein the organic light-emitting diode display comprises a plurality of pixel columns corresponding to the cathode lines;

wherein pixels in the same pixel column have a same color, the cathode lines corresponding to the pixel columns having different colors are inputted with different cathode voltages, respectively;

the organic light-emitting diode display further comprises a voltage supply module configured to supply cathode voltages, and the cathode lines connect to the voltage supply module.

2. The organic light-emitting diode display according to claim 1, wherein an end of the cathode lines connects to the voltage supply module.

3. The organic light-emitting diode display according to claim 1, wherein two ends of the cathode lines connect to the voltage supply module.

4. The organic light-emitting diode display according to claim 1, wherein the voltage supply module comprises a first voltage supply unit configured to supply a first cathode voltage, a second voltage supply unit configured to supply a second cathode voltage, and a third voltage supply unit configured to supply a third cathode voltage;

the pixel columns comprises a red pixel column, a green pixel column, and a blue pixel column, wherein the cathode line corresponding to the red pixel column connects to the first voltage supply unit, the cathode line corresponding to the green pixel column connects to the second voltage supply unit, and the cathode line corresponding to the blue pixel column connects to the third voltage supply unit.

5. The organic light-emitting diode display according to claim 1, wherein the cathode lines are formed by an evaporation process.

6. The organic light-emitting diode display according to claim 1, wherein the organic light-emitting diode display further comprises a switch array layer located under the anode layer, and the switch array layer comprises a plurality of switch elements.

7. The organic light-emitting diode display according to claim 1, wherein the organic light-emitting diode display further comprises an encapsulation layer located on the cathode layer.

8. The organic light-emitting diode display according to claim 1, wherein the organic light-emitting diode display is a top emission type or a bottom emission type.

9. An organic light-emitting diode display, comprising: an anode layer;

an organic layer disposed on the anode layer; and

a cathode layer disposed on the organic layer and comprising a plurality of cathode lines, wherein the organic light-emitting diode display comprises a plurality of pixel columns corresponding to the cathode lines;

wherein pixels in the same pixel column have the same color, the cathode lines corresponding to the pixel columns having different colors are inputted with different cathode voltages, respectively.

10. The organic light-emitting diode display according to claim 9, wherein the organic light-emitting diode display further comprises a voltage supply module configured to supply cathode voltages, and the cathode lines connect to the voltage supply module.

11. The organic light-emitting diode display according to claim 10, wherein an end of the cathode lines connects to the voltage supply module.

12. The organic light-emitting diode display according to claim 10, wherein two ends of the cathode lines connect to the voltage supply module.

13. The organic light-emitting diode display according to claim 10, wherein the voltage supply module comprises a first voltage supply unit configured to supply a first cathode voltage, a second voltage supply unit configured to supply a second cathode voltage, and a third voltage supply unit configured to supply a third cathode voltage;

the pixel columns comprises a red pixel column, a green pixel column, and a blue pixel column, wherein the

cathode line corresponding to the red pixel column connects to the first voltage supply unit, the cathode line corresponding to the green pixel column connects to the second voltage supply unit, and the cathode line corresponding to the blue pixel column connects to the third voltage supply unit.

14. The organic light-emitting diode display according to claim 9, wherein the cathode lines are spaced apart from each other.

15. The organic light-emitting diode display according to claim 9, wherein the cathode lines are formed by an evaporation process.

16. The organic light-emitting diode display according to claim 9, wherein the organic light-emitting diode display further comprises a switch array layer located under the anode layer, and the switch array layer comprises a plurality of switch elements.

17. The organic light-emitting diode display according to claim 9, wherein the organic light-emitting diode display further comprises an encapsulation layer located on the cathode layer.

18. The organic light-emitting diode display according to claim 9, wherein the organic light-emitting diode display is a top emission type or a bottom emission type.

* * * * *

专利名称(译)	有机发光二极管显示器		
公开(公告)号	US20190058151A1	公开(公告)日	2019-02-21
申请号	US15/577247	申请日	2017-10-26
[标]申请(专利权)人(译)	深圳市华星光电技术有限公司		
[标]发明人	ZENG WEIJING HAN BAIXIANG		
发明人	ZENG, WEIJING HAN, BAIXIANG		
IPC分类号	H01L51/52 H01L51/50 H01L27/32		
CPC分类号	H01L51/5221 H01L51/5206 H01L51/5036 H01L27/3276 H01L27/3213 H01L2251/5307 H01L27/3211 H01L51/5203		
优先权	201710699528.6 2017-08-16 CN		
其他公开文献	US10529944		
外部链接	Espacenet USPTO		

摘要(译)

提供一种有机发光二极管显示器。有机发光二极管显示器具有阳极层，设置在阳极层上的有机层，以及设置在有机层上并包括多个阴极线的阴极层。有机发光二极管显示器包括与阴极线对应的多个像素列。同一像素列中的像素具有相同的颜色，并且对应于具有不同颜色的像素列的阴极线分别输入不同的阴极电压。

